

T. T. Omorov¹, Corresponding-Member of the NAS KR, Dr. Tech. Sc., Head of the Laboratory, omorovtt@mail.ru,
K. E. Zakiriae², Senior Teacher, kubz1@mail.ru,
B. K. Takyrbashev¹, Cand. Sc., Senior Researcher, b.takyrbashev@gmail.com,
Zh. S. Imanakunova³, Cand. Sc., Associate Professor, j.imanakunova@kstu.kg,
¹ Institute of Mechanical Engineering and Automation, National Academy
of Science of Kyrgyz Republic (NAS KR), Bishkek, 720071, Kyrgyz Republic,
² IssyKul State University, Karakol, 722200, Kyrgyz Republic,
³ Kyrgyz State Technical University, Bishkek, 720044, Kyrgyz Republic

Corresponding author: **Omorov T. T.**, Dr. Tech. Sc., Head of the Laboratory, Institute of Mechanical Engineering and Automation of the NAS KR, Bishkek, 720071, Kyrgyz Republic, e-mail: omorovtt@mail.ru

Accepted on September 27, 2022

Automated Control of Unauthorized Power Take-Offs in a Distributed Electrical Network

Abstract

A distributed electrical network (DEN) with a voltage of 0.4 kV operating in an unsymmetric mode is considered as an object of automated control. The problem of identification of places and control of unauthorized power take-offs (UPTO) in the DEN in the conditions of functioning of the automated system of control and accounting of electricity (ACMSE) is formulated. The primary source information for its solution is the data obtained from the head and subscriber electricity meters by synchronized remote measurements at discrete points in time. This problem belongs to the class of problems in which there is significant uncertainty about the current state of the object under study and the parameters of external disturbing influences, which are unauthorized consumers of electricity. Under these conditions, the primary measurement data on the characteristics of the network subscribers' loads received from the counters of the automated system and recorded in its database are insufficient to solve the problem under consideration. In this regard, in order to reduce the level of uncertainty and obtain additional necessary information about the state of the object, the concept of a virtual DEN model is introduced into consideration, designed to describe its desired state, which is determined by the absence of these external random disturbances in the network. A new method for solving the formulated problem is proposed, based on the concept of a virtual DEN model. The conditions for identifying the current state of the DEN have been obtained. For this purpose, the desired input phase currents of the virtual network are determined by introducing equivalent complex resistances of certain parts of the three-phase network. The vectors of the effective values of currents and voltages on the loads of subscribers and inter-subscriber sections of the virtual network are identified. Criterion functions are introduced that determine the deviations of the corresponding components of the stress vectors on the loads of subscribers of the real DEN and its virtual model. Based on these functions, an identification criterion and an algorithm for monitoring unauthorized power take-offs in a three-phase distributed network are formulated. The obtained results are oriented for the creation of algorithmic and special software for the subsystem of automated control of UPTO as part of the ACMSE.

Keywords: distributed network, virtual network, unauthorized power take-off, identification and control method

For citation:

Omorov T. T., Zakiriae K. E., Takyrbashev B. K., Imanakunova Zh. S. Automated Control of Unauthorized Power Take-Offs in a Distributed Electrical Network, *Mekhatronika, Avtomatizatsiya, Upravlenie*, 2023, vol. 24, no. 1, pp. 24–32.

DOI: 10.17587/mau.24.24-32

УДК 620.9: 681.5

DOI: 10.17587/mau.24.24-32

Т. Т. Оморов¹, чл.-корр. НАН КР, д-р техн. наук, зав. лабораторией, omorovtt@mail.ru,
К. Э. Закиряев², ст. преподаватель, kubz1@mail.ru,
Б. К. Такырбашев¹, канд. техн. наук, ст. науч. сотр., b.takyrbashev@gmail.com,
Ж. С. Иманакунова³, канд. техн. наук, доц., j.imanakunova@kstu.kg,
¹ Национальная академия наук Кыргызской Республики (НАН КР),
Институт машиноведения и автоматики, г. Бишкек,
² Иссык-Кульский государственный университет, г. Каракол,
³ Кыргызский государственный технический университет, г. Бишкек

Автоматизированный контроль несанкционированных отборов мощностей в распределенной электрической сети

В качестве объекта автоматизированного контроля рассматривается распределенная электрическая сеть (РЭС) напряжением 0,4 кВ, функционирующая в несимметричном режиме. Формулируется задача идентификации мест и

контроля несанкционированных отборов мощностей (НОМ) в РЭС в условиях функционирования автоматизированной системы контроля и учета электроэнергии (АСКУЭ). Первичной исходной информацией для ее решения являются данные, полученные с головного и абонентских счетчиков электроэнергии путем синхронизированных дистанционных измерений в дискретные моменты времени. Данная проблема относится к классу задач, в которых имеется существенная неопределенность о текущем состоянии исследуемого объекта и параметрах внешних возмущающих воздействий, в качестве которых выступают несанкционированные потребители электроэнергии. В указанных условиях первичные измерительные данные о характеристиках нагрузок абонентов сети, полученные со счетчиков автоматизированной системы и записанные в ее базу данных, являются недостаточными для решения рассматриваемой задачи. В связи с этим в целях снижения уровня неопределенности и получения дополнительной необходимой информации о состоянии объекта в рассмотрение вводится понятие виртуальной модели РЭС, предназначенной для описания ее желаемого состояния, которое определяется отсутствием в сети указанных внешних случайных возмущений. Предложен новый метод решения сформулированной задачи, основанный на концепции виртуальной модели РЭС. Получены условия для идентификации текущего состояния РЭС. Для этой цели определены входные желаемые фазные токи виртуальной сети путем введения эквивалентных комплексных сопротивлений определенных частей трехфазной сети. Идентифицированы векторы действующих значений токов и напряжений на нагрузках абонентов и межабонентских участках виртуальной сети. Введены критериальные функции, определяющие отклонения соответствующих компонентов векторов напряжений на нагрузках абонентов реальной РЭС и ее виртуальной модели. На основе указанных функций сформулирован критерий идентификации и алгоритм контроля несанкционированных отборов мощностей в трехфазной распределенной сети. Полученные результаты ориентированы для создания алгоритмического и специального программного обеспечения подсистемы автоматизированного контроля НОМ в составе АСКУЭ.

Ключевые слова: распределенная сеть, виртуальная сеть, несанкционированный отбор мощности, метод идентификации и контроля

Introduction

Electricity generated by generating systems is supplied to its consumers through low-voltage distributed electric networks (DEN). One of the main indicators of the quality and efficiency of DEN is the loss of electricity in them, which is caused by a number of factors. The latter, along with the asymmetry of currents and voltages [1–3] and the nonlinear properties of individual loads [4, 5] of subscribers of three-phase networks, also include uncontrolled current leakage in them, including unauthorized power take-offs (UPTO) [6–8]. The volumes of UPTO in certain periods of time reach significant values.

As is known, in recent years, in order to automate information processes in DEN, new digital technologies have been widely introduced in the form of automated control and metering systems for electricity (ACMSE) [9, 10], which are elements of Smart Grid technology [11, 12]. An analysis of the functional structure of modern ACMSEs shows that they are mainly designed to implement the functions of commercial electricity metering, and therefore belong to the class of information-measuring systems. As part of these automated systems, there are no algorithmic and software tools aimed at solving a set of tasks to minimize power losses in the distribution zone. It can be noted that the specified complex includes the tasks of optimizing the operating

modes of the DEN due to their balancing [13–17], as well as the tasks of identifying and controlling the UPTO. To date, a number of methods and methods have been proposed [7, 18–21] aimed at identifying and identifying the places of UPTO in a distributed network. However, the practical application of these methods as part of existing ACMSEs presents certain difficulties due to the difficulties in their software implementation in real time. The article proposes a new method for automated control of unauthorized power takeoffs in DEN based on the development of the approaches described in [8, 22].

Problem statement

As an object, a four-wire DEN with a voltage of 0.4 kV is considered, the design scheme of which is shown in Fig. 1, where k, v — index variables denoting,

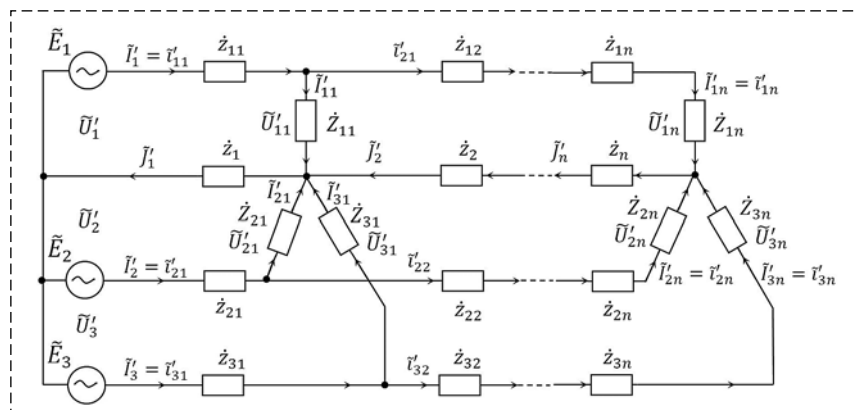

Fig.1. Calculation scheme of a three-phase network

The current values of the currents I_k^o , $k = \overline{1,3}$, at the inputs of the phases of the virtual network will be called the desired phase currents. A comparative analysis of the structures of the original DEN (Fig. 1) and the virtual network (Fig. 2) shows that the following relations hold for their input complex phase currents:

$$\dot{I}'_k = \dot{I}_k^o + \dot{I}_k^x, \quad k = \overline{1,3},$$

where \dot{I}_k^x — the complex current on the load of an unauthorized consumer connected to the phase with number k .

Identification of the current state of the network

According to the conditions of the problem under consideration, the current values of phase currents $I'_k = I'_k(t_0)$ at the input of the original real distributed network (Fig. 1) at the time $t = t_0$ are measured by the main three-phase meter, which are contained in the ACMSE database. The analysis shows that to identify the current state of the DEN, it is advisable to use the following conditions:

$$|I'_k - I_k^o| \leq \Delta I, \quad k = \overline{1,3}, \quad (2)$$

where ΔI — the maximum allowable error in measuring currents in ACMSE.

It is obvious that if at least one of the relations (2) is not fulfilled, there are UPTOs in the network, and their fulfillment means that the DEN is operating in the normal mode. Thus, relations (2) can be used as a criterion condition for identifying the current state of the DEN. Now let's set the task of estimating the values of the input desired phase currents I_k^o , $k = \overline{1,3}$, on the virtual network.

Estimation of the input desired phase currents of the virtual network. Consider a virtual network, the scheme of which is shown in Fig. 2.

For this purpose, we introduce into consideration the concepts of equivalent complex resistances \dot{Z}_{kv}^{equ} , determined for individual parts of a three-phase network, an illustration of which for the end sections of the k -th phase is shown in Fig. 3, a, b, c.

The indicated equivalent resistances, as can be seen from the figures, are the total resistances of the subsequent sections of the network, starting at nodes with coordinates (k, v) :

$$\dot{Z}_{kv}^{equ} = \frac{\dot{U}_{kv}}{\dot{I}_{kv}} = Z_{kv}^{equ} e^{j\varphi_{kv}^{equ}}, \quad k = \overline{1,3}, \quad v = \overline{1,n}, \quad (3)$$

where Z_{kv}^{equ} , φ_{kv}^{equ} — the modulus and phase \dot{Z}_{kv}^{equ} . In this case, the following formulas are valid for the modules:

$$Z_{kv}^{equ} = \frac{U_{kv}}{I_{kv}}, \quad k = \overline{1,3}, \quad n = \overline{1,n}. \quad (4)$$

With known values of network load resistances \dot{Z}_{kv} and intersubscriber sections \dot{z}_{kv} and \dot{z}_v , to determine the introduced equivalent resistances, you can use the formula for determining the total resistance of the series-parallel connection of circuits starting from the end sections of the DEN [23]. Wherein

$$\dot{Z}_{k,n-1}^{equ} = \frac{\dot{Z}_{k,n-1}(\dot{z}_{kn} + \dot{z}_n + \dot{Z}_{kn})}{\dot{Z}_{k,n-1} + \dot{z}_{kn} + \dot{z}_n + \dot{Z}_{kn}},$$

$$\dot{Z}_{k,n-2}^{equ} = \frac{\dot{Z}_{k,n-2}(\dot{z}_{k,n-1} + \dot{z}_{n-1} + \dot{Z}_{k,n-1}^{equ})}{\dot{Z}_{k,n-2} + \dot{z}_{k,n-1} + \dot{z}_{n-1} + \dot{Z}_{k,n-1}^{equ}}.$$

In the general case, the equivalent resistances \dot{Z}_{kv}^{equ} of series circuits (sections), determined by expressions (3), starting from nodes with coordinates (k, v) , are calculated by the formulas:

$$\dot{Z}_{kv}^{equ} = \frac{\dot{U}_{kv}}{\dot{I}_{kv}} = \frac{\dot{Z}_{kv}(\dot{z}_{k,v+1} + \dot{z}_{v+1} + \dot{Z}_{k,v+1}^{equ})}{\dot{Z}_{kv} + \dot{z}_{k,v+1} + \dot{z}_{v+1} + \dot{Z}_{k,v+1}^{equ}}, \quad (5)$$

$$k = \overline{1,3}, \quad v = \overline{1, n-1},$$

where $\dot{Z}_{kn}^{equ} = \dot{Z}_{kn}$.

To estimate the desired input phase currents I_k^o of the virtual network, it is first necessary to determine the total phase resistances \dot{Z}_k (Fig. 2):

$$\dot{Z}_k = \frac{\dot{U}_k}{\dot{I}_k^o} = Z_k e^{j\varphi_k}, \quad k = \overline{1,3}, \quad (6)$$

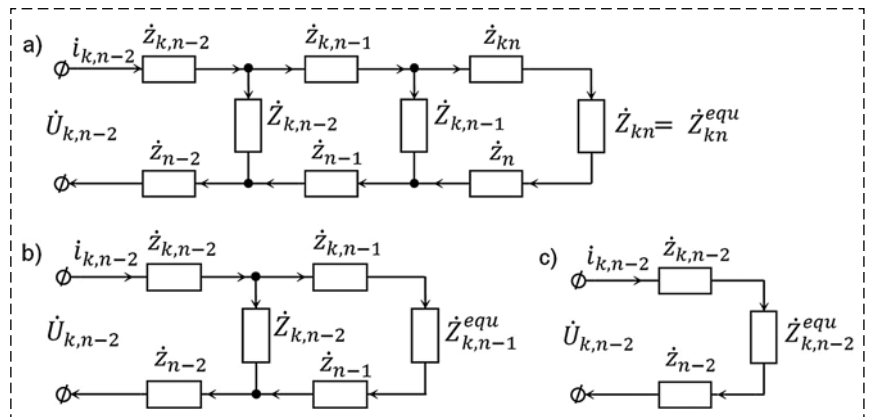

Fig. 3. Illustration of equivalent resistances \dot{Z}_{kv}^{equ}

where Z_k, φ_k — the modulus and phase of resistance \dot{Z}_k . Moreover, they are determined through equivalent resistances \dot{Z}_{k1}^{equ} :

$$\dot{Z}_k = \dot{Z}_{k1}^{equ}. \quad (7)$$

Here we note that the load resistances of subscribers \dot{Z}_{kv} are calculated from the data of subscriber electricity meters, and inter-subscriber resistances \dot{z}_{kv} and \dot{z}_v can be preliminarily identified using, for example, the methods described in [24, 25]. However, this approach leads to a number of difficulties in the practical implementation of the procedure for searching for places of unauthorized consumers. In particular, for this purpose, a sufficiently large amount of memory in the ACMSE database will be required, and it is also necessary to set a more detailed structure of the distribution network. In this regard, it is more appropriate to evaluate the inter-subscriber resistances directly in the process of identifying places of unauthorized power takeoff (UPTO).

Assessment of intersubscriber resistances. It can be noted that the determination of the complex resistances \dot{z}_{kv} and \dot{z}_v presents certain computational difficulties. In this regard, it is advisable to approximate the representation of these resistances. As is known, in the general case, the resistance of inter-subscriber sections of the network \dot{z}_{kv}, \dot{z}_v can be represented in a complex form:

$$\begin{aligned} \dot{z}_{kv} &= z_{kv}^B + jz_{kv}^M = z_{kv} e^{j\varphi_v}, \quad k = \overline{1,3}, \quad v = \overline{1,n}, \\ \dot{z}_v &= z_v^B + jz_v^M = z_v e^{j\varphi_v}, \quad k = \overline{1,3}, \quad v = \overline{1,n}, \end{aligned}$$

where $z_{kv}, z_v, \varphi_{kv}, \varphi_v, z_{kv}^B, z_v^B, z_{kv}^M, z_v^M$ — the modules, phases, real and imaginary parts of \dot{z}_{kv} and \dot{z}_v respectively. Applied calculations for estimating the values z_{kv}^B, z_v^B and z_{kv}^M, z_v^M of inter-subscriber sections of a number of trunk lines of three-phase networks show that the values of active resistances z_{kv}^B and z_v^B are approximately two orders of magnitude greater than the values of reactive resistances z_{kv}^M and z_v^M . Therefore, we can approximately assume that

$$\begin{aligned} \dot{z}_{kv} &\approx z_{kv} \approx z_{kv}^B, \quad k = \overline{1,3}, \quad n = \overline{1,n}, \\ \dot{z}_v &\approx z_v \approx z_v^B, \quad k = \overline{1,3}, \quad n = \overline{1,n}. \end{aligned} \quad (8)$$

To determine z_{kv} and z_v , you can use information about the lengths of wires of intersubscriber sections of the network and their passport data. Further, we denote by L_{kv} the length of the wire between the corresponding neighboring subscribers of the network. Now suppose that the phase and neutral wires have different cross sections. Then, the active resis-

tances of these intersubscriber sections are determined by the formulas:

$$\begin{aligned} z_{kv} &= \rho_1 L_{kv}, \\ z_v &= \rho_2 L_{kv}, \quad k = \overline{1,3}, \quad v = \overline{1,n}, \end{aligned} \quad (9)$$

where ρ_1, ρ_2 — the specific resistances of the phase and neutral wires, respectively.

With this approach, in order to evaluate the inter-subscriber resistances determined by formulas (8) and (9), it is necessary to have data on the lengths of wires in the inter-subscriber sections of a three-phase network in the ACMSE database.

Estimation of the input phase currents of the virtual network

For this purpose, consider a virtual model of the k -th phase, the scheme of which is shown in Fig. 2. As is known, the functional relationships between the e.m.f. \dot{E}_k of the mains power supply and voltage \dot{U}_k at the phase inputs are determined by the relations:

$$\dot{E}_k = \dot{U}_k + \dot{I}_k^o \dot{z}_B, \quad k = \overline{1,3}, \quad (10)$$

where \dot{z}_B — the internal resistance of the source, which can be represented in a complex form:

$$\dot{z}_B = z_B e^{j\varphi_B},$$

where the numerical values of the module z_B and the argument φ_B are determined by the passport data of the transformer. Now, taking into account the fact that stresses $\dot{U}_k = \dot{I}_k^o \dot{Z}_k$, relations (10) can be represented as:

$$\dot{E}_k = \dot{I}_k^o (\dot{Z}_k + \dot{z}_B), \quad k = \overline{1,3}.$$

From here we get

$$\frac{\dot{E}_k}{\dot{I}_k^o} = \dot{Z}_k + \dot{z}_B, \quad k = \overline{1,3}, \quad (11)$$

where \dot{Z}_k is the total complex resistance of the k -th virtual phase, determined by formulas (6) and (7). Now, we will write the variables included in the last expressions in exponential form:

$$\begin{aligned} \dot{Z}_k &= Z_k e^{j\varphi_k}, \\ \dot{I}_k^o &= I_k^o e^{j(\beta_k + \alpha_k)}, \\ \dot{E}_k &= E_k e^{j(\beta_k + \hat{\psi}_k)}, \quad k = \overline{1,3}, \end{aligned} \quad (12)$$

where Z_k, I_k^o, E_k — the modules of the corresponding complex variables; φ_k — resistance argument \dot{Z}_k ; $\alpha_k, \hat{\psi}_k$ — deviations of the phase shifts

of the corresponding currents and e.m.f from their base values β_k .

Further, to estimate the input phase desired currents I_k^o , relations (11), taking into account (12), we write in exponential form:

$$\frac{E_k e^{j(\beta_k + \hat{\psi}_k)}}{I_k^o e^{j(\beta_k + \alpha_k)}} = \dot{Z}'_k, k = \overline{1,3}, \quad (13)$$

where

$$\dot{Z}'_k = Z_k e^{j\varphi_k} + z_B e^{j\theta_B} = Z'_k e^{j\theta_k}.$$

Here Z'_k and θ_k are known real numbers. Note that the value of the e.m.f. E can be preliminarily determined from the data \dot{I}_k and \dot{Z}_k obtained from the readings of the head three-phase meter at time $t = t_0$. As a result, relation (13) will be written as:

$$\frac{E_k e^{j\lambda_k}}{I_k^o} = Z'_k e^{j\theta_k}, k = \overline{1,3}.$$

From this it can be seen that the following relations must be satisfied:

$$\frac{E_k}{I_k^o} = Z'_k, \lambda_k = \theta_k, k = \overline{1,3},$$

where the phase shift differences $\lambda_k = \hat{\psi}_k - \alpha_k$.

As a result, the desired input currents I_k^o of the virtual network are determined by the formulas

$$I_k^o = \frac{E_k}{Z'_k}, k = \overline{1,3}. \quad (14)$$

Identification of the vectors of currents and voltages of the virtual DEN

Now let's set the task of determining the vectors $\bar{U}_k = [U_{k1}, U_{k2}, \dots, U_{kn}]$ and $\bar{I}_k = [I_{k1}, I_{k2}, \dots, I_{kn}]$, which determine the state of the virtual network. Note that the modules of equivalent resistances Z_{k1}^{equ} were found earlier. Then, based on formulas (4), we calculate the voltages U_{k1} (Fig. 2):

$$U_{k1} = I_{k1} Z_{k1}^{equ}, k = \overline{1,3},$$

where $I_{k1} = I_k^o, k = \overline{1,3}$.

Then the effective currents I_{k1} on the loads of virtual subscribers with resistance Z_{k1} can be found by the formulas:

$$I_{k1} = \frac{U_{k1}}{Z_{k1}}, k = \overline{1,3},$$

where Z_{k1} — the modulus of complex resistance \dot{Z}_{k1} .

Next, the effective values of the intersubscriber currents I_{k2} are calculated (Fig. 2). For this purpose, consider the balance relations for currents in nodes with coordinate $(k, 1)$:

$$i_{k2} = i_{k1} - \dot{I}_{k1}, k = \overline{1,3}.$$

It is easy to show that the following expressions are true for the squares of the modules of currents i_{k2} :

$$\begin{aligned} I_{k2}^2 &= (i_{k1} - \dot{I}_{k1})(i_{k1} - \dot{I}_{k1})^* = \\ &= (i_{k1} - \dot{I}_{k1})(i_{k1}^* - \dot{I}_{k1}^*) = \\ &= i_{k1} i_{k1}^* + \dot{I}_{k1} \dot{I}_{k1}^* - (i_{k1} \dot{I}_{k1}^* + \dot{I}_{k1} i_{k1}^*), k = \overline{1,3}, \end{aligned}$$

the components of which can be determined by the formulas:

$$i_{k1} i_{k1}^* = I_{k1}^2, \dot{I}_{k1} \dot{I}_{k1}^* = I_{k1}^2,$$

$$\begin{aligned} i_{k1} \dot{I}_{k1}^* + \dot{I}_{k1} i_{k1}^* &= i_{k1} I_{k1} (e^{j(\alpha_{k1} - \tilde{\alpha}_{k1})} + e^{-j(\alpha_{k1} - \tilde{\alpha}_{k1})}) = \\ &= i_{k1} I_{k1} (e^{j(\alpha_{k1} - \tilde{\alpha}_{k1})} + e^{-j(\alpha_{k1} - \tilde{\alpha}_{k1})}) = 2I_{k1} I_{k1} \cos \lambda_{k1}, \end{aligned}$$

where I_{k1}, I_{k1} — the effective values of the currents flowing through the corresponding resistances \dot{z}_1 and \dot{Z}_{k1} , and the parameter λ_{k1} is determined by the expression

$$\lambda_{k1} = \alpha_{k1} - \tilde{\alpha}_{k1}, k = \overline{1,3}.$$

Since \dot{Z}_{kv}^{equ} is determined by formula (5), then for $v = 1$ the following relation is true:

$$\frac{\dot{I}_{k1}}{i_{k1}} = \frac{\dot{Z}_{k1}^{equ}}{Z_{k1}},$$

which, taking into account (1) and (3), has the form:

$$\frac{I_{k1}}{I_{k1}} e^{j\lambda_{k1}} = \frac{Z_{k1}^{equ}}{Z_{k1}} e^{j(\varphi_{k1}^{equ} - \varphi_{k1})}.$$

From here we obtain the values of the phase differences:

$$\lambda_{k1} = \varphi_{k1}^{equ} - \varphi_{k1}.$$

As a result, the following formula holds for I_{k2}^2 :

$$\begin{aligned} I_{k2}^2 &= I_{k1}^2 + I_{k1}^2 - I_{k1} I_{k1} (e^{j\lambda_{k1}} + e^{-j\lambda_{k1}}) = \\ &= I_{k2}^2 + I_{k1}^2 - 2I_{k1} I_{k1} \cos \lambda_{k1}, k = \overline{1,3}. \end{aligned}$$

From here we obtain the numerical values of I_{k2} :

$$I_{k2} = \sqrt{I_{k1}^2 + I_{k1}^2 - 2I_{k1} I_{k1} \cos \lambda_{k1}}, k = \overline{1,3}.$$

Now, in a similar way, we determine the parameters U_{k2} and I_{k2} of virtual loads having coordinates $(k, 2)$ according to the following formulas:

$$U_{k2} = I_{k2} Z_{k2}^{equ},$$

$$I_{k2} = \frac{U_{k2}}{Z_{k2}}, k = \overline{1, 3}.$$

Further, continuing the above computational procedure for $v = 3, 4, \dots, n$, we determine the remaining voltages U_{kv} and currents I_{kv} on the loads of the virtual network. Note that the general iterative formula for calculating the intersubscriber currents I_{kv} has the form:

$$I_{kv} = \sqrt{I_{k,v-1}^2 + I_{k,v-1}^2 - I_{k,v-1} I_{k,v-1} \cos \lambda_{k,v-1}},$$

$$k = \overline{1, 3}, v = \overline{1, n},$$

and the desired voltages and currents are determined by the following formulas:

$$U_{kv} = I_{kv} Z_{kv}^{equ}, I_{kv} = \frac{U_{kv}}{Z_{kv}}, k = \overline{1, 3}, v = \overline{1, n},$$

where

$$\lambda_{k,v-1} = \varphi_{k,v-1}^{equ} - \varphi_{k,v-1},$$

$$I_{kn} = I_{kn}.$$

As a result of using the technique considered above, we obtain the desired values of all components of the vectors $\bar{U}_k = [U_{k1}, U_{k2}, \dots, U_{kn}]$ and $\bar{I}_k = [I_{k1}, I_{k2}, \dots, I_{kn}]$.

Construction of an identification criterion and algorithm

For this purpose, on the basis of the found estimates of the input phase currents I_k^o of the virtual network, it is necessary to first analyze the relations (2). Let us assume that these conditions are not satisfied for all $k(k = \overline{1, 3})$, i.e., there are single unauthorized power takeoffs in the network in all its phases. Note that the AC-MSE database contains the vectors $\bar{U}'_k = [U'_{k1}, U'_{k2}, \dots, U'_{kn}]$, $k = \overline{1, 3}$, which are preliminarily determined on the basis of data obtained from subscriber meters systems. In addition, the vectors $\bar{U}_k = [U_{k1}, U_{k2}, \dots, U_{kn}]$, characterizing the state of the virtual network, were identified above (Fig. 2).

$$\Delta U_{kv} = |\bar{U}_{kv} - \bar{U}'_{kv}|, k = \overline{1, 3}, v = \overline{1, n}. \quad (17)$$

Now, let's assume that unauthorized power withdrawals in the network are carried out in the vicinity of the nodes of a real DEN, having coordinates (k, m_k) , which is conditionally shown in Fig. 4, where $v = m_k$ and $m_k < n$.

In this case, each phase of a three-phase network with respect to these nodes can be conditionally divided into two parts. Obviously, throughout the first (initial) part of the k -th phase of the DEN, the current I_k^x of an unauthorized consumer additionally flows through its intersubscriber sections, and in the second section, i.e. after the point (k, m_k) , the indicated current is absent. A comparative analysis of the processes in the considered parts of the network shows that in the initial sections of each phase of the network, the values of the voltage differences ΔU_{kv} , where $v = \overline{1, m_k}$, differ significantly from the values of the differences $\Delta U_{k\xi}$, $\xi = \overline{m_{k+1}, n}$ related to areas where there are no UPTOs. Moreover, the values ΔU_{kv} for the initial sections of the network are much larger than $\Delta U_{k\xi}$ calculated for the second part of the network, i.e.

$$\Delta U_{kv} \gg \Delta U_{k\xi}, v = \overline{1, m_k}, \xi = \overline{m_{k+1}, n}. \quad (18)$$

An illustration of this situation using a graph of the discrete (lattice) function ΔU_{kv} is shown in Fig. 5.

Now we introduce discrete functions F_{kv} defined by the following differences:

$$F_{kv} = |\Delta U_{kv} - \Delta U_{k,v+1}|, v = \overline{1, n-1}. \quad (19)$$

The set of values F_{kv} for a given k is the vector $F_k = [F_{k1}, F_{k2}, \dots, F_{k,n-1}]$. The analysis shows that,

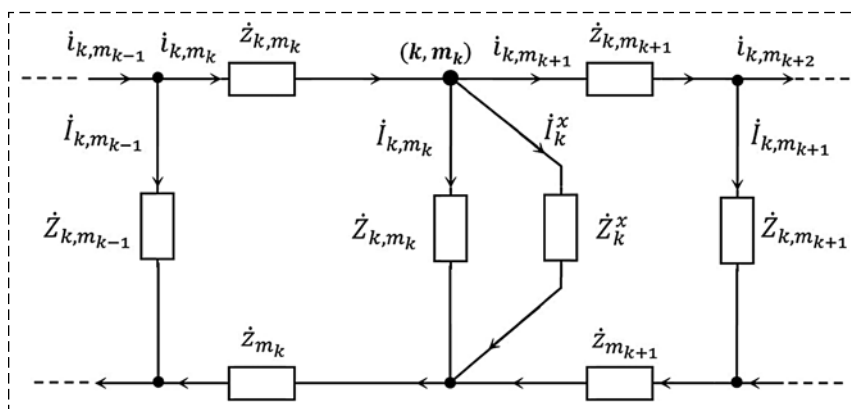

Fig. 4. Conditional fragment of the network where UPTO is carried out

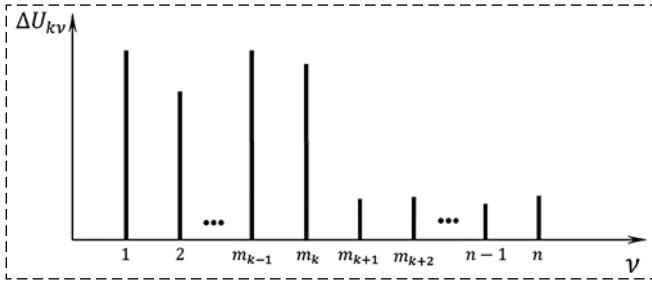

Fig. 5. Graphical representation of the function ΔU_{kv}

taking into account relations (18) and the condition $m_k < n$, the graphic representation of the function F_{kv} is presented in the form shown in Fig. 6.

As can be seen from the figure, the UPTO coordinate in the k -th phase of the network is determined based on the solution of the following extremal problem:

$$\max_{v \in V} F_{kv} = F_{k, m_k}, \quad k = \overline{1, 3}, \quad (20)$$

where m_k — the number of the node of the k -th phase, in the vicinity of which an unauthorized power take-off is observed; V — a discrete subset consisting of network subscriber numbers, i.e. $V = \{1, 2, \dots, n\}$. As a result, the extremal problem (20) is reduced to finding the maximum element of the vector $F_k = [F_{k1}, F_{k2}, \dots, F_{k, n-1}]$, $k = \overline{1, 3}$, which is solved by fairly simple means. It is easy to see that when $m_k = n$ in the graph of the function F_{kv} (Fig. 6) there will be no "impulse that has an excessively large amplitude. This means that if conditions (2) are not met, UPTO is carried out in the final section of the k -th phase with the coordinate (k, n) .

Thus, the introduction of the concept of a virtual model of a distributed network and the procedure proposed above for constructing discrete functions F_{kv} make it possible to identify the places of unauthorized power takeoffs in the DEN. At the same time, the system of discrete functions (17) and (19) can be used to construct an identification criterion for UPTO, which can be formulated as fol-

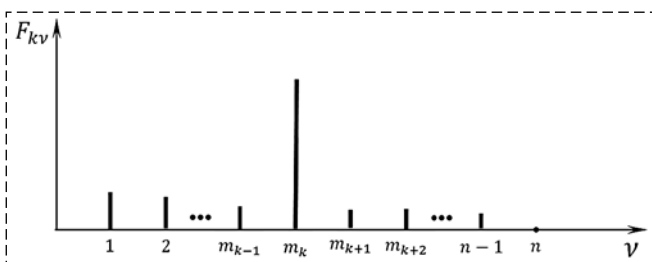

Fig. 6. Graphic representation of the function F_{kv}

lows: the coordinates of unauthorized consumers in the DEN are determined based on the analysis of the structure of the functions F_{kv} , $v = \overline{1, n}$, $k = \overline{1, 3}$, in particular, by solving the extremal problem (20).

The results obtained above allow us to formulate the following UPTO control algorithm in a distributed three-phase network.

1. Cyclic interrogation of the main three-phase and subscriber electricity meters of ACMSE at a discrete time.

2. Recording the information received from the counters in the ASKUE database and forming the vectors $\bar{U}'_k = [U'_{k1}, U'_{k2}, \dots, U'_{kn}]$, $k = \overline{1, 3}$.

3. Formation of a virtual model of DEN (Fig. 2).

4. Determination of the input phase currents of the virtual network I_k^o , $k = \overline{1, 3}$, according to formulas (14).

5. Identification of the current state of the distribution network by checking conditions (2).

6. If relations (2) are satisfied, go to step 1. Otherwise, go to step 7.

7. Estimation of intersubscriber resistances z_{kv} , $k = \overline{1, 3}$, $v = \overline{1, n}$, trunk line, in particular, according to formulas (9), if they are not previously identified and are not contained in the ACMSE database.

8. Calculation of equivalent resistances Z_{kv}^{equ} , $k = \overline{1, 3}$, $v = \overline{1, n}$, defined by expressions (5).

9. Identification of virtual network parameters, i.e. estimation of intersubscriber currents I_{kv} , $k = \overline{1, 3}$, $v = \overline{1, n}$, according to formulas (15), as well as current vectors $\bar{I}_k = [I_{k1}, I_{k2}, \dots, I_{kn}]$ and voltages $\bar{U}_k = [U_{k1}, U_{k2}, \dots, U_{kn}]$, whose components are calculated by formulas (16).

10. Calculation of stress differences ΔU_{kv} , $k = \overline{1, 3}$, $v = \overline{1, n}$, determined by formulas (17).

11. Formation of discrete functions F_{kv} , $k = \overline{1, 3}$, $v = \overline{1, n}$, according to formulas (19) and vectors $F_k = [F_{k1}, F_{k2}, \dots, F_{k, n-1}]$.

12. Analysis of the structure of the criterial functions F_{kv} ($k = \overline{1, 3}$, $v = \overline{1, n}$), in particular, the solution of the extremal problem (20).

13. On the basis of this analysis, the implementation of operational control of unauthorized power take-offs in the DEN.

14. End of the UPTO monitoring process in the network and go to step 1.

Conclusion

The practice of operating distributed electrical networks (DEN) with a voltage of 0.4 kV shows that

they can experience significant losses of electricity in certain periods of time due to unauthorized power take-offs (UPTO). As part of the ACMSE hardware and software systems, which are implemented in low-voltage networks for the purpose of automating and informatizing the processes of monitoring and accounting for electricity, there are no technical and software tools designed to identify and control unauthorized power take-offs in the DEN. A new method and algorithm for solving this problem are proposed based on the concept of a virtual model of a three-phase network. The latter was introduced to describe the desired state of a real network, to the phases of which unauthorized consumers of electricity are connected. The computational procedure of the developed algorithm, in contrast to existing methods, is more adapted for use as part of ACMSE in real time. The results obtained can be used to create a subsystem for automated control of DEN as part of ACMSE.

References

1. **Kosoukhob F. D., Vasilev N. V., Filipov A. O.** Reducing losses from current unbalance and improving electric-energy quality in 0.38-Kv networks with municipal loads, *Russian electrical engineering*, Allerton Press, Inc. (New York), 2014, vol. 85, no. 6, pp. 350–353.
2. **Czarnecki L. S., Bhattarai P. D.** Currents' physical components (CPC) in three-phase systems with asymmetrical voltage, *Przegld Elektrotechniczny*, 2015, no.6, pp. 40–47, doi: 10.15199/48.2015.06.06.
3. **Averbuh M. A., Zhilin E. B.** About electric power losses in systems of electrosupply of individual housing construction, *Energetic*, 2016, no.6. pp. 54–56 (in Russian).
4. **Harutyunyan A. G.** On the calculation of additional power losses in three-phase four-wire networks, *Electricity*, 2015, no. 10, pp. 55–58 (in Russian).
5. **Zhelezko Y. S.** Electricity losses. Reactive power. Power quality, M., ENAS, 2009, 456 p. (in Russian).
6. **Sapronov A. A., Kuzhekov S. L., Tynyansky V. G.** Emergency reveal of unmonitored power consumption in up to 1 kv electrical networks, *Russian Electromechanics*, 2004, no. 1, pp. 55–58 (in Russian).
7. **Danilov M. I., Romanenko I. G.** Identification of unauthorized electricity consumption in the phases of distribution networks with automated metering systems, *Elektricheskie Stancii*, 2022, no. 2 (1087), pp. 10–19 (in Russian).
8. **Omorov T. T.** To the problem of localization of unauthorized selection of the electric power in distributive networks as a part of ASCAE, *Instruments and Systems: Monitoring, Control, and Diagnostics*, 2017, no. 7, pp. 27–32 (in Russian).
9. **Yakushev K. V.** Automat system of the commercial account of the electric power for the retail market Information and control systems in the industry, *The Young scientis*, 2009, no. 3 (23), pp. 9–13 (in Russian).
10. **Eremina M. A.** Development of automatic systems of the commercial account of power resources, *The Young scientist*, 2015, no. 3, pp. 135–138 (in Russian).
11. **Buchholz B. M., Stychinski Z. A.** Smart Grids — fundamentals and technologies in electricity networks, Moscow, MEI, 2017, 461 p. (in Russian).
12. **Stephen Bush F.** Smart Grid: Communication-Enabled Intelligence for the Electric Power Grid, John Wiley & Sons Limited, 2018, 572 p.
13. **Kiselyov M. G., Lepanov M. G.** Simmetrirovanie of currents in electrosupply networks a power electric regulator of inactive capacity, *The Electrical engineer*, 2018, no. 11, pp. 63–70 (in Russian).
14. **Omorov T. T., Takyrbashev B. K., Koibagrov T. D.** Electricity Losses Management in Distribution Network as a Composition of Automated Meter Reading and Control System (AMRCS), *Mekhatronika, Avtomatizatsiya, Upravlenie*, 2021, vol. 22, no. 4, pp. 191–199 (in Russian).
15. **Omorov T. T., Takyrbashev K., Zakiriaev K. E., Koibagrov T. Zh.** Digital control of electric power flows in non-symmeter distribution networks as a composition of AM-RCS, *Energy Systems Research*, 2021, no. 1, pp. 38–46.
16. **Samokish V. V.** The patent № 2548656 (Russian Federations). Sposob of balancing of phase currents of a three-phase four-wire line and the device for its realization, *Biull*, no. 11. 27.12.2013 (in Russian).
17. **Naumov I. V., Ivanov D. A., Podjachih S. V.** The patent № 2490768 (Russian Federations). The symmetrizing device for three-phase networks with a zero wire, *Biull*, no. 23. 20.08.2013 (in Russian).
18. **Tariq M., Poor H. V.** Electricity Theft Detection and Localization in Grid-Tied Microgrids, *IEEE Transactions on Smart Grid*, 2018, vol. 9, no. 3, pp. 1920–1929, doi: 10.1109/TSG.2016.2602660
19. **Kirankumar T., Sri Madhu G. N.** Power theft detection using probabilistic neural network classifier, *International Research Journal of Engineering and Technology*, 2018, vol. 5, no. 8, pp. 834–838.
20. **Jeyaranjani J., Devaraj D.** Machine learning algorithm for efficient power theft detection using smart meter data, *International Journal of Engineering & Technology*, 2018, vol. 7, no. 3, pp. 900–904.
21. **Messinis G. M., Rigas A. E., Hatzigiorgiou N. D.** A Hybrid Method for Non-Technical Loss Detection in Smart Distribution Grids, *IEEE Transactions on Smart Grid*, 2019, vol. 10, no. 6, pp. 6080–6091, doi: 10.1109/TSG.2019.2896381
22. **Omorov T. T., Takyrbashev B. K.** Identification of the State of the Distributive Electrical Network in the Automated Systems of Accounting and Management of the Power Consumption, *Mekhatronika, Avtomatizatsiya, Upravlenie*, 2016, vol. 17, no. 10, pp. 651–656 (in Russian).
23. **Demirchjan K. S., Nejman L. R., Korovkin A. V.** Theoretical of a basis electrical engineers. Vol.1, SPb., Peter, 2009, 512 p. (in Russian).
24. **Kononov Y.** Refinement of the parameters of sections of lines of the medium voltage network according to the data of synchronous measurements, *Russian Electromechanics*, 2018, vol. 61, no. 1, pp. 77–84 (in Russian).
25. **Omorov T. T., Osmonova R. Ch., Takyrbashev B. K., Imanakunova Zh. S.** Methodology for identification of the parameters of the trunk line of the distribution network according to ASKUE data, *Kazan state power engineering university bulletin*, 2021, no. 3(51), pp. 168–177 84 (in Russian).